

## ⚠️ IMPORTANT

### READ BEFORE YOU BEGIN INSTALLATION

**IT IS CRITICAL FOR YOUR SAFETY THAT YOU CAREFULLY READ AND FOLLOW THE SAFETY CAUTIONS AND INSTALLATION INSTRUCTIONS BOTH PRIOR TO AND DURING INSTALLATION.**

#### USER SAFETY CAUTION

During installation, be mindful of the potential for sharp edges on the product or vehicle. Taking proper safety precautions helps ensure a safe and smooth installation process.

**Always wear protective gloves and handle components with care to reduce the risk of injury.**



#### TEMPERATURE SURFACE CAUTION

During high temperatures or extended sun exposure, surfaces of this product may become hot to the touch, posing a risk of burns or injury. Use caution when handling the product in hot weather and allow time for it to cool before contact.

**Always check surface temperature before use to ensure safe handling conditions.**



#### FASTENER TORQUE CAUTION

All fasteners must be tightened to the specified torque values provided in the installation instructions to ensure proper fit and safe operation of the tonneau cover. Under- or over-tightening can lead to product failure, potential damage to your vehicle, injury, or safety hazards while driving.

**Always use a calibrated torque wrench and follow the specifications in the installation instructions.**

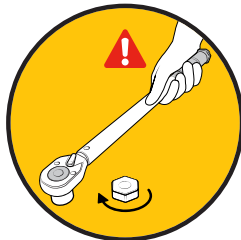

#### PINCH POINT SAFETY CAUTION

This tonneau cover may create pinch points when closing or operating near solid surfaces such as the truck bed rails or tailgate. To prevent injury, keep hands, fingers, and other body parts clear of moving parts during operation.

**Always operate the cover slowly and with caution to ensure safe and proper use.**



## ! IMPORTANT

### READ BEFORE YOU BEGIN INSTALLATION

**IT IS CRITICAL FOR YOUR SAFETY THAT YOU CAREFULLY READ AND FOLLOW THE SAFETY CAUTIONS AND INSTALLATION INSTRUCTIONS BOTH PRIOR TO AND DURING INSTALLATION.**

#### ENTRAPMENT SAFETY WARNING

This tonneau cover does not feature a manual release mechanism from inside the truck bed. To prevent the risk of entrapment, never allow anyone to be inside the bed of the truck when the cover is closed.

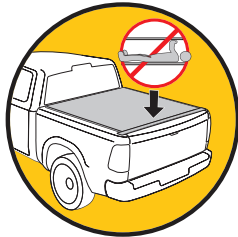

**Always ensure the area is clear before closing the cover, and keep the cover securely latched when not in use to avoid accidental closure.**

#### COVER ATTACHMENT WARNING

A partially rolled up or unsecured cover may detach during transit, risking vehicle or property damage and personal injury.

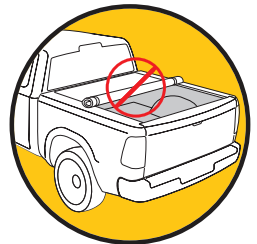

**Always verify the tonneau cover is properly secured before operating the vehicle.**

#### CARGO TRANSPORT WARNING

When transporting cargo that is taller than the truck bed, the cover must be fully rolled open and securely fastened with both retainer straps. An unsecured cover can detach while driving, risking vehicle or property damage and personal injury.



**Never operate the vehicle with a partially rolled up cover.**

#### COVER POSITION WARNING

Before operating the vehicle, always verify the tonneau cover is either fully rolled open and secured with both retainer straps or fully rolled closed and securely latched down.

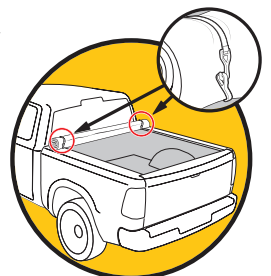

**Never operate the vehicle if the tonneau cover is not properly secured.**

**NOTE:** It is important that all areas where the bed cover mounts are clean and free of debris prior to installing.

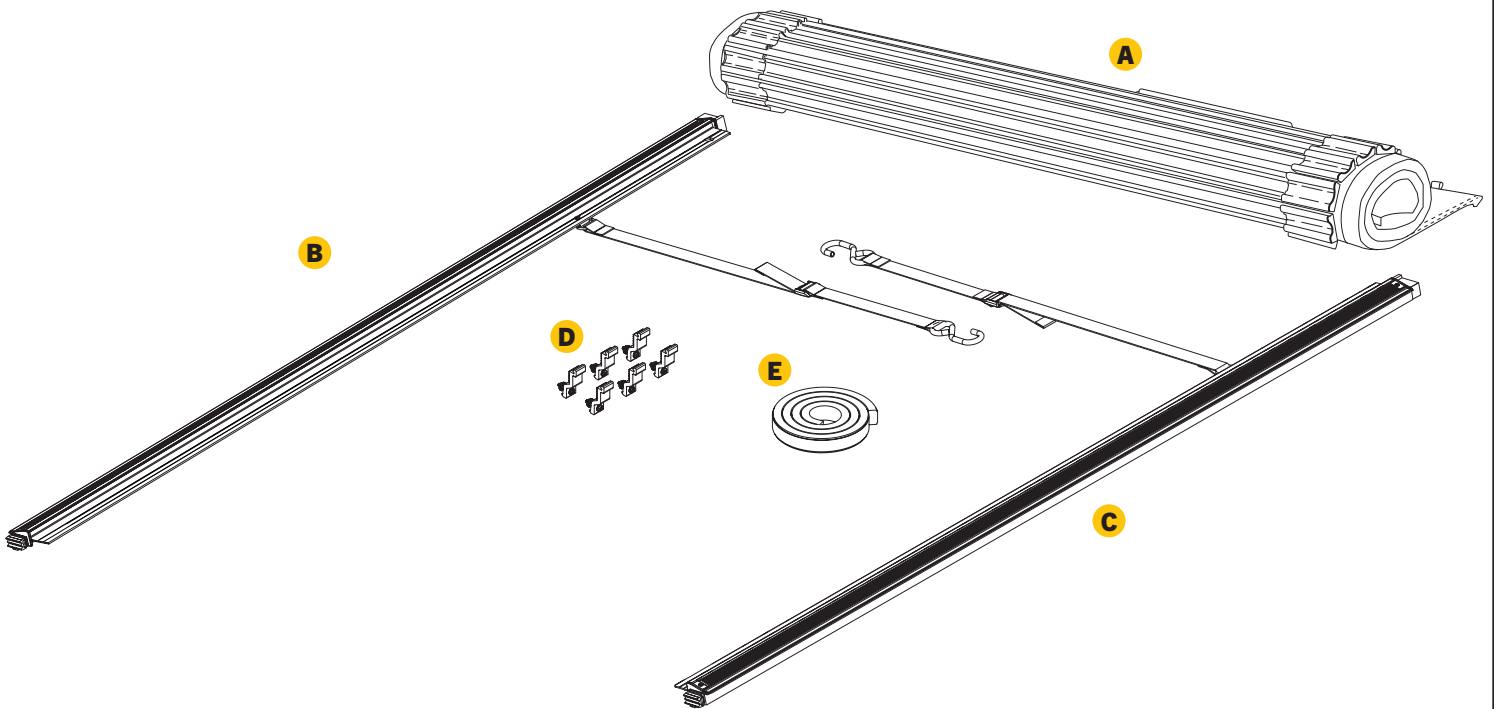

### TOOLS REQUIRED

- 1/2" Wrench or socket
- Isopropyl alcohol
- Scissors/utility knife

### PARTS INCLUDED IN YOUR KIT:

- **A** 1x Cover assembly
- **B** 1x Driver side rail
- **C** 1x Passenger side rail
- **D** 6x Clamps
- **E** 1x Bulkhead seal  
(on select make/models)

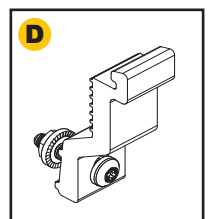

**1** The serial number for the cover is located here.

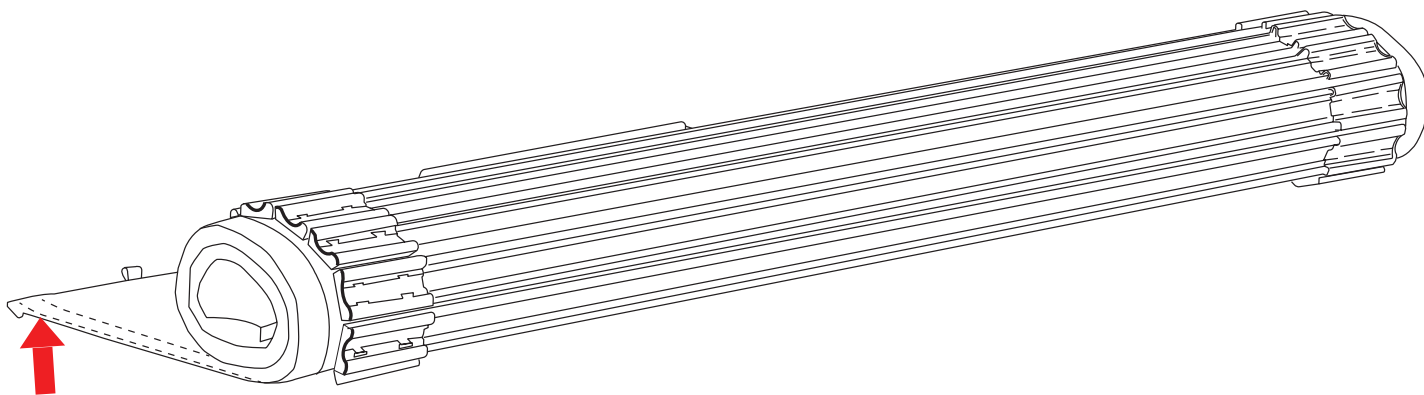

For future reference, write it here:

\_\_\_\_\_.

**2** Remove three of the four factory plastic clips as shown below. Unscrew the center first, then pry out the entire clip. These will not be used again unless you permanently remove the bed cover assembly. **Caution:** Be careful when removing plastic clips. These clips are screwed in and at times from the factory are stripped out making them a bit more difficult to remove.

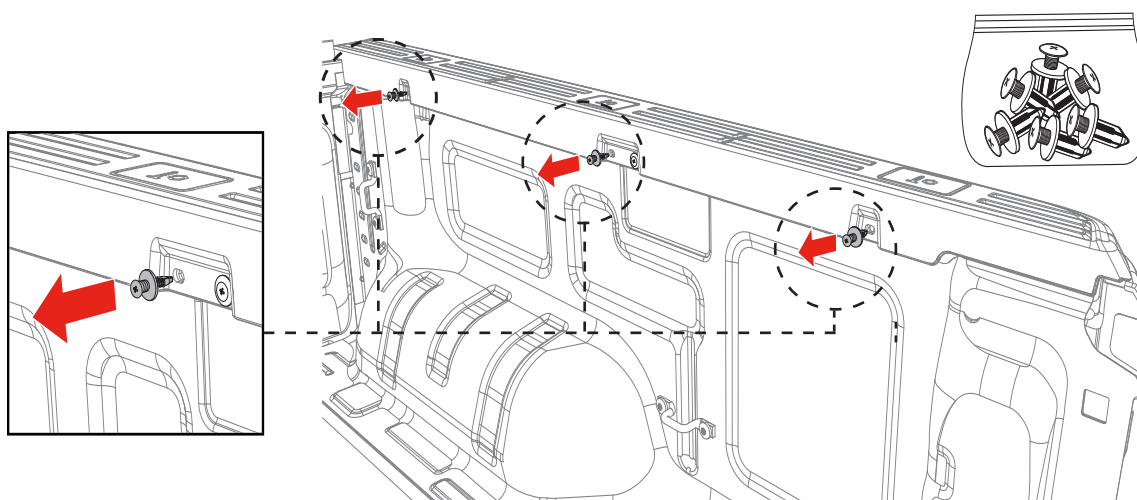

**3** Install the six clamp brackets (D) to the truck box in the locations where you removed the factory plastic clips from in step 3. The lock nut from clamp (D) goes behind the plastic bed cap and sheet metal of the truck. Leave hardware loose at this time.

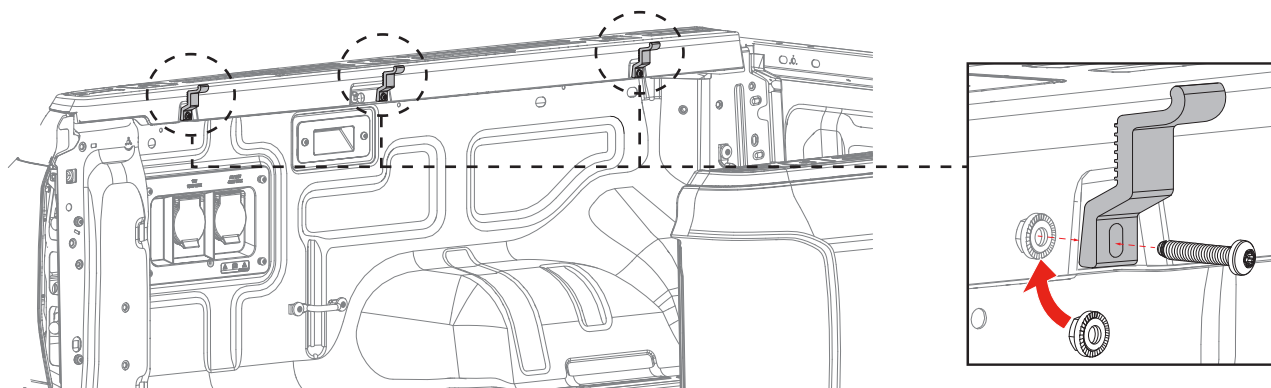

**4** Position the driver side rail (B) on the trucks bed rail, making sure to center it between the tailgate and cab.

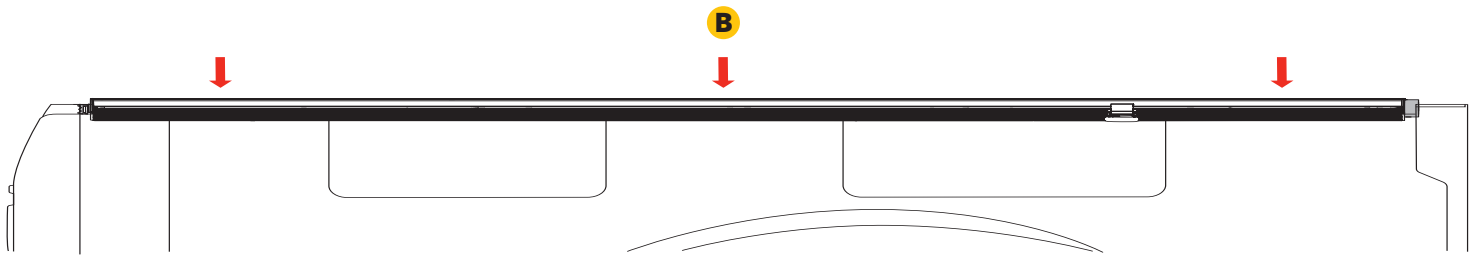

**5** Align drivers side rail (A) so foam is compressed equally on both sides. Compress foam spacer approximately 50%.

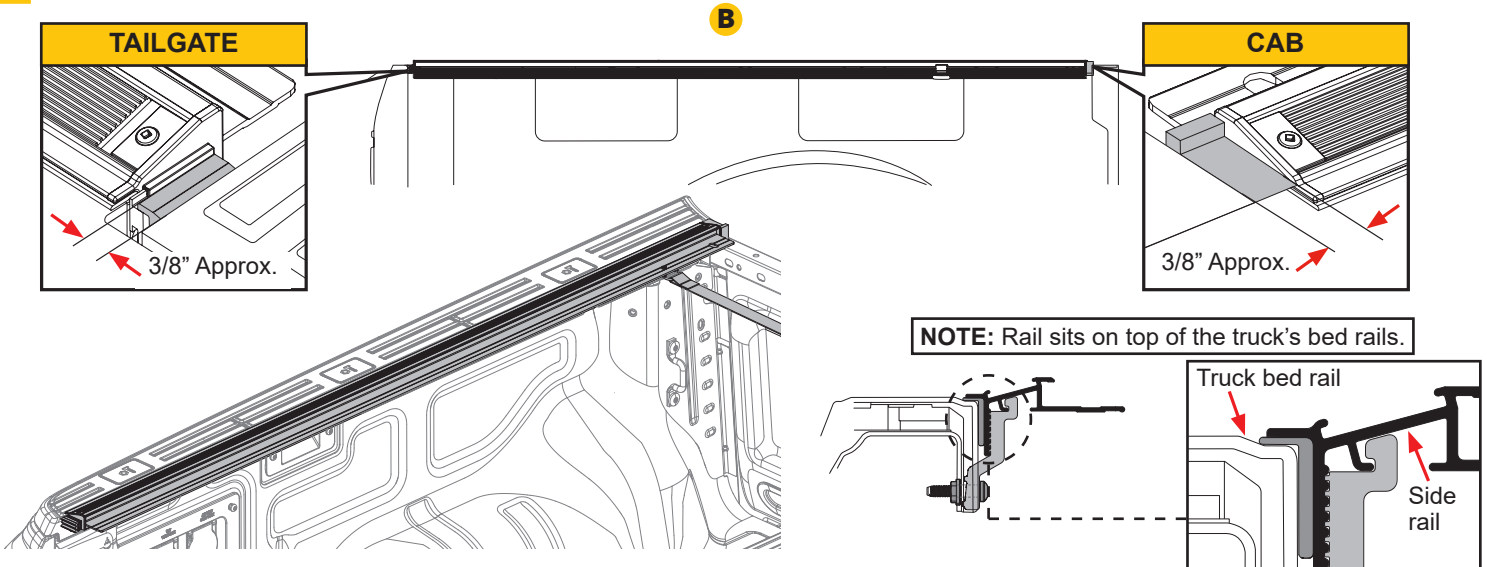

**6** For optimal latching performance and cover fit, the side rails (A & B) should be level with the truck bed caps and not tilted up or down. To fine-tune side rail tilt, you can reposition the clamps. To adjust the rail tilt upwards or downwards. Tighten all clamps with a T-30 drive socket or T-handle wrench.

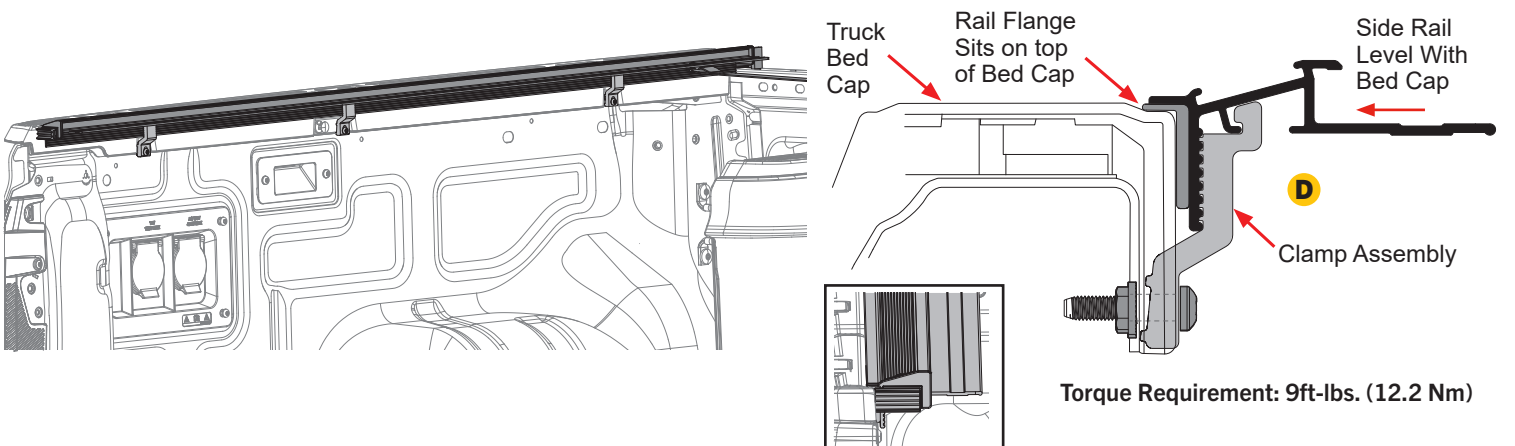

**NOTE:** The use of spring clamps to hold the side rail in place can assist during the installation process.



- 7** To ensure cover assembly (A) is square for proper operation, make sure attachment holes on the driver and passenger side rails (B & C) are lined up across from each other.

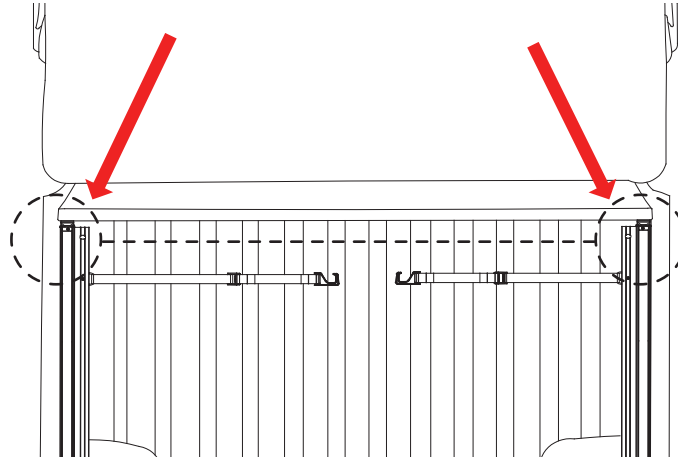

- 8** Install the bulkhead seal. Clean the top of the bulkhead where the seal will go with soap and water to remove dirt and debris. Then clean the same area with isopropyl alcohol to remove wax or grease and to evaporate any remaining water. Allow the surface to dry. The seal should be placed flush with the front edge of the bulkhead and should be snug between the truck bed rails. Peel the backing paper from the bulkhead seal (E) and apply pressure to the entire seal to make sure that the adhesion is good.

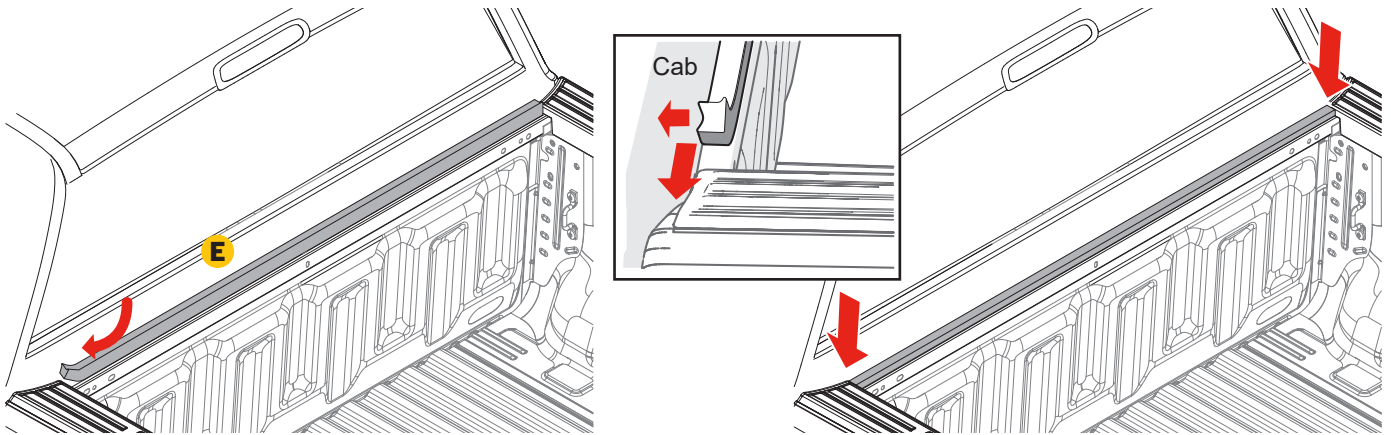

- 9** Place the cover assembly (A) on the side rails (B & C) towards the front of the truck bed (near the cab).

**NOTE:** The rail may need to be forced upward slightly to allow the screw head to drop in the slot.

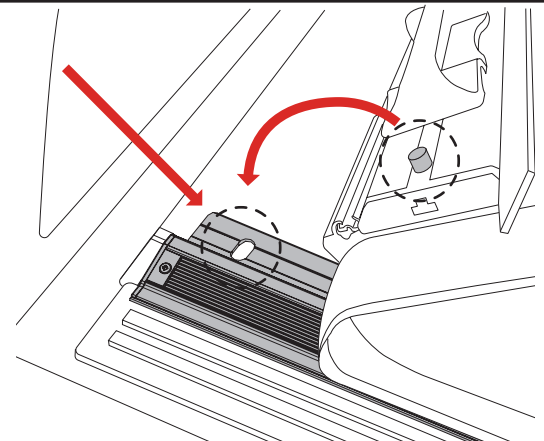
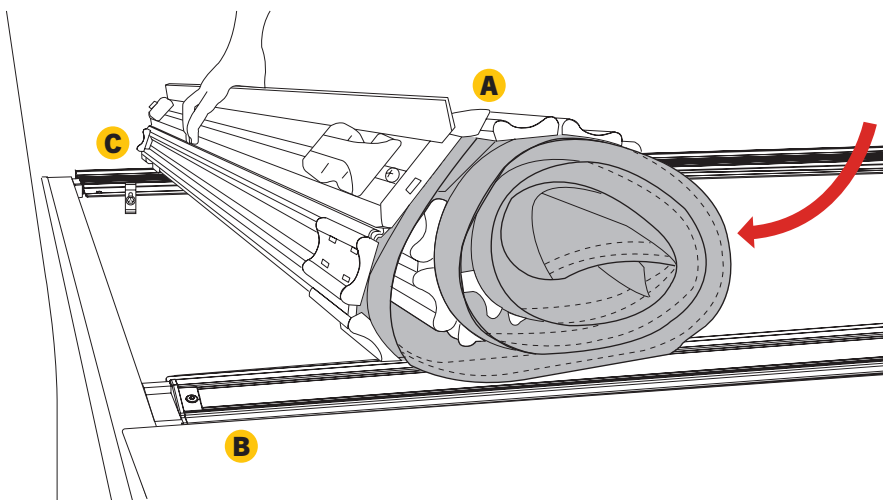

**10** To connect the cover assembly (A) to the side rails (B & C), slide the right and left header guides into the locked position. A clicking sound will indicate a secure attachment.

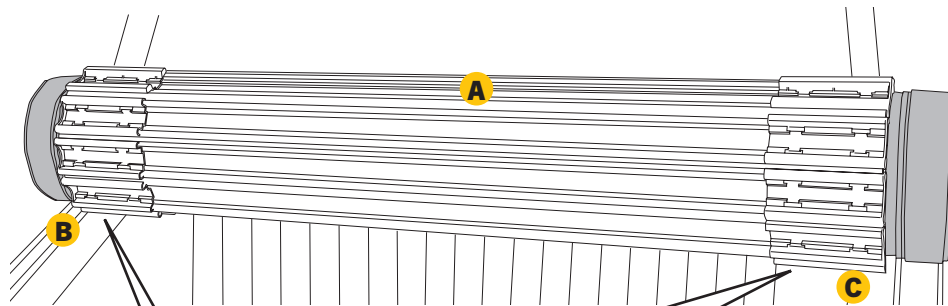

**NOTE:** The rail may need to be forced upward slightly to allow the header guides to slide.

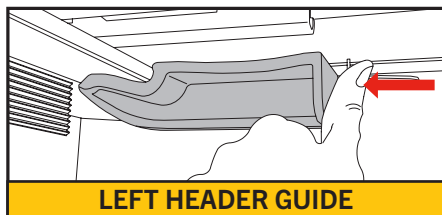

**LEFT HEADER GUIDE**

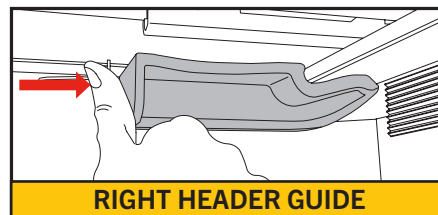

**RIGHT HEADER GUIDE**



**11** Unroll cover to tailgate.

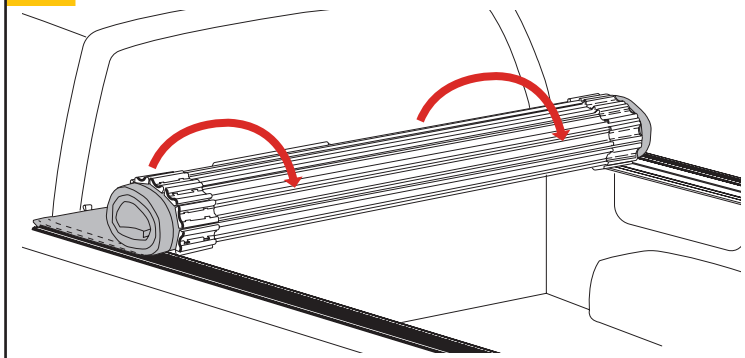

**12** Push down on both ends of the cover (A), near the tailgate, to latch the driver and passenger slam latches. A clicking sound will indicate a correctly installed cover.

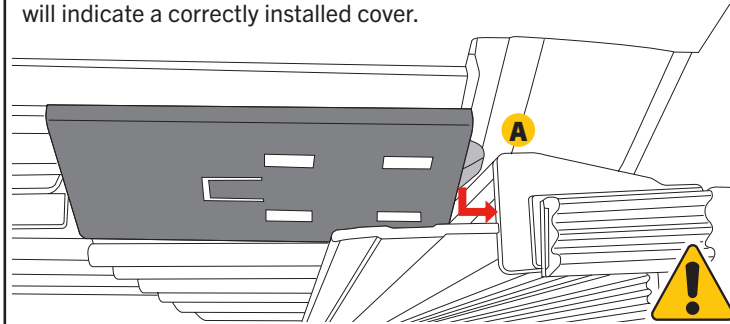

**13 Preferred method of closure:** Close tailgate, then close cover on top of tailgate. This method will not work with some truck applications. Use alternative method instead.

**Alternative method of closing cover:** Close and latch cover, then close tailgate with the seal inside the tailgate. It will take a little time to train the seal to close on the inside.

**PREFERRED**

**ALTERNATIVE**

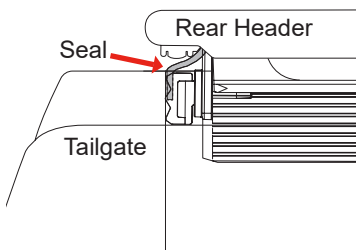
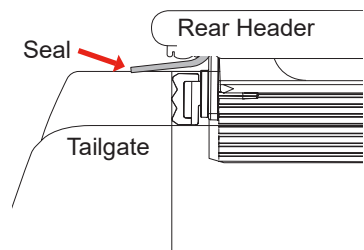

**NOTE:** If you have a key lock tailgate, the truck bed cover is secured until the tailgate is unlocked and opened.

**NOTE:** Make sure cover is securely latched on both sides before operating vehicle.

**14** Secure the hook and loop down both sides along the entire length of the truck bed cover before driving the vehicle. This will prevent wind from lifting the cover and causing damage.

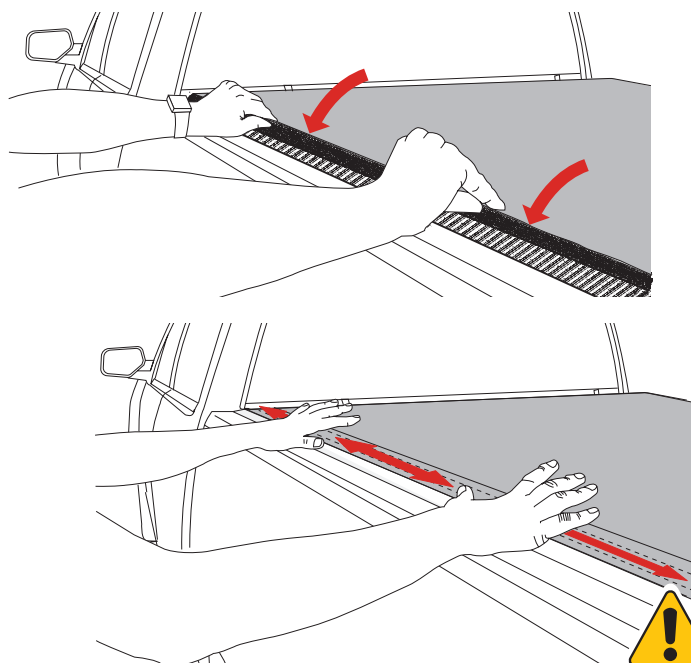

### ATTENTION:

After the initial installation leave cover closed and latched for 24 hour period. This will ensure that the fabric has completely set to the metal substrate.

### OPENING THE COVER

To open cover, pull down on release cable and hold down. Lift and roll tail header toward the cab.

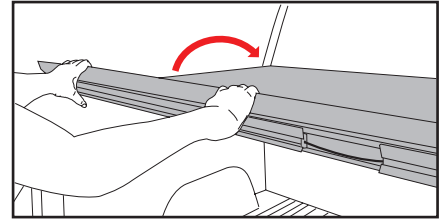
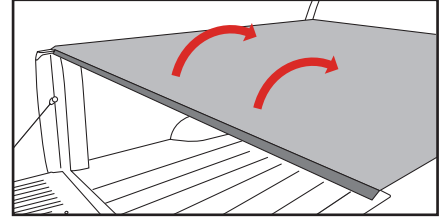
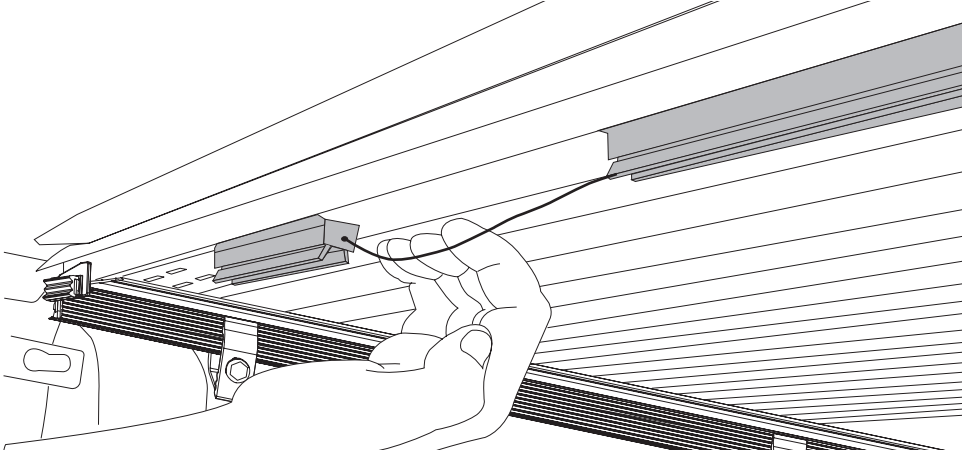

### SECURING THE COVER

Roll cover tight. Secure the cover appropriately using both retainer straps. Do not over tighten. Do not stow cover against cab window.

Before driving with the cover open, both straps must be secured to retaining loops. Failure to do so could cause accidental release of the cover, resulting in personal injury or property damage.

To release strap push tab up. **NOTE:** Ice buildup within hinge sections can occur if cover is stowed in open position. To prevent potential damage, close cover during winter precipitation.

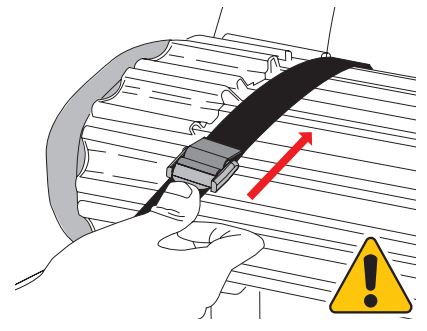
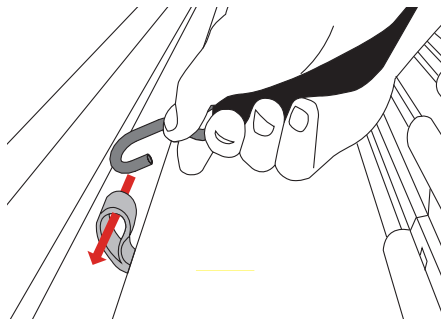
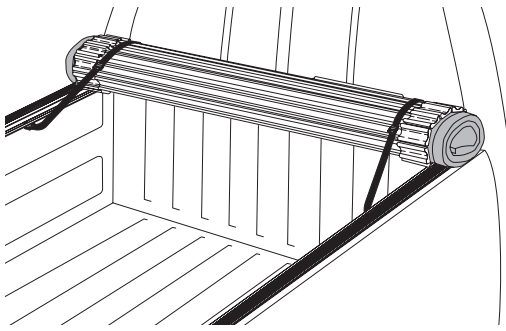

# LIMITED WARRANTY

## WARRANTY COVERAGE

This truck bed cover is warranted against defects in materials or workmanship as follows. This warranty is void if the product has been damaged in an accident, or due to neglect, unforeseeable use, improper installation, improper servicing, or other cause not arising out of defects in material or workmanship.

### SENTRY: LIMITED THREE-YEAR WARRANTY ON HARD PARTS

All hardware included with your truck bed cover, including rails, clamps and bows carry a limited warranty for **three (3) years** from the original date of purchase, subject to the terms below.

### SENTRY: LIMITED THREE-YEAR WARRANTY FOR FABRIC

The fabric on your truck bed cover carries a limited warranty for **three (3) years** from the original date of purchase, subject to the terms below.

### SENTRY CT: LIMITED FIVE-YEAR WARRANTY ON HARD PARTS

All hardware included with your truck bed cover, including rails, clamps and bows carry a limited warranty for **five (5) years** from the original date of purchase, subject to the terms below.

### SENTRY CT: LIMITED FIVE-YEAR WARRANTY FOR FABRIC

The fabric on your truck bed cover carries a limited warranty for **five (5) years** from the original date of purchase, subject to the terms below.

## WARRANTY IS NOT TRANSFERABLE

The warranty is to the initial owner purchasing the truck bed cover and it is not transferable to a subsequent end user. Proof of purchase may be required to enforce these warranty rights.

## WARRANTY CONDITIONS

Failure to follow these warnings and care instructions will void the warranty:

- Clean with mild automotive soap and water only.
- Do not use conditioners that contain silicone or petroleum.
- The tonneau cover must be secured at all points when the vehicle is in motion. When not fully closed with the rear latch engaged the cover must be completely rolled up and secured at the cab with both provided retainer straps attached. Do NOT drive with the bed cover in a partially open position.
- Do NOT tie cargo to truck bed cover framework.
- Check rail clamps for tightness after a week of driving following the installation of the cover and periodically thereafter.
- Do NOT roll the cover into the rear cab window. Do NOT stow the cover against the cab of the truck.
- If the cover is going to be rolled open for an extended amount of time, periodically re-roll the cover and secure the retainer straps to ensure the cover doesn't rest against the cab of the truck.
- Before opening, the cover must be free of all foreign materials including snow and ice.
- Do NOT tow your vehicle from the rear with the cover on your vehicle. If towing from the rear is required, the cover MUST be removed from the vehicle and properly stored.

## WARRANTY PERFORMANCE

If all warranty conditions are met, a defective truck bed cover, tarp, or hardware component will either be repaired or replaced (at our option). We reserve the right, for any warranty, to substitute a newer model of bed cover having similar form and function, to offer a warranty discount on an entire replacement system, and/or provide remedies other than those mentioned in this document.

## WARRANTY PROCESS

A Return Material Authorization number must be obtained from our Customer Service Department prior to returning any product. We may require the original item to be returned postage prepaid for final determination. Shipping charges will apply for any repair or replacement. Other than postage or shipping charges, no charge will be made for repair or replacement under this warranty.

This warranty gives you specific legal rights. As an owner, you may also have additional rights and remedies under the laws of your state.

## WARRANTY REGISTRATION

Warranty registration must be on file and/or proof of original purchase (detailed and dated receipt) required for warranty to be effective.

Register online at <https://realtruck.com/truxedo-warranty/>

**REGISTER  
YOUR  
WARRANTY  
ONLINE**



## SAFETY INSTRUCTIONS

- DO NOT place objects on or against cover or framework.
- DO NOT tie cargo to truck bed cover framework.
- Never allow children or pets to occupy pickup box while cover is closed.
- Cover is not airtight. Special care is required to keep cargo clean and dry.
- Tonneau covers won't prevent theft of contents inside truck box.
- DO NOT stow rolled cover against cab window.
- DO NOT attempt to drive with the cover in the partially open position!
- A fully rolled open cover must always be secured with retainer straps.
- DO NOT operate vehicle with objects on top of the cover.
- CAUTION - Pinch points can cause serious personal injury.
- CAUTION - Metal parts can get extremely hot if left in bright sun and or heat.

## TROUBLESHOOTING TIPS

### COVER ASSEMBLY WILL NOT ATTACH TO SIDE RAILS DURING INSTALLATION

- Check side rails to make sure they are level.
- The rolled-up cover is heavy which may be flexing the rails downward. Push front of rail up slightly to allow the screw head to fall in the slot and the header guide to slide freely into the secured location.
- If rear header doesn't latch correctly check side rail installation.

### HEADER WILL NOT LATCH

Check side rails to make sure they are level.

Make sure the rear header seal is not caught between side rail & rear header.

If rear header doesn't latch correctly check side rail installation.

Check to make sure side rails are both equally spaced front to rear.

Make sure both latches are functioning properly. Clean any debris that may be impeding latches.

## COVER CARE AND MAINTENANCE

- Clean with mild automotive soap and water. Do not use vinyl conditioners because they will shrink the vinyl. The cover can be cleaned in a car wash. Never use vinyl conditioners that contain silicon, petroleum, or citrus based products on your truck bed cover as they may crack and shrink the vinyl top surface.
- It is recommended that you periodically check that the cover is securely attached to your truck bed. Inspect the clamps and front header guide slides to ensure they were properly installed and have not come loose during operation.
- It is recommended that you periodically inspect and service the rear latch closures. Clean away any excess dirt or grime and lubricate with silicone spray.
- Covers that are used frequently or are subject to vibrations and impacts from rough roadways may require adjustment.

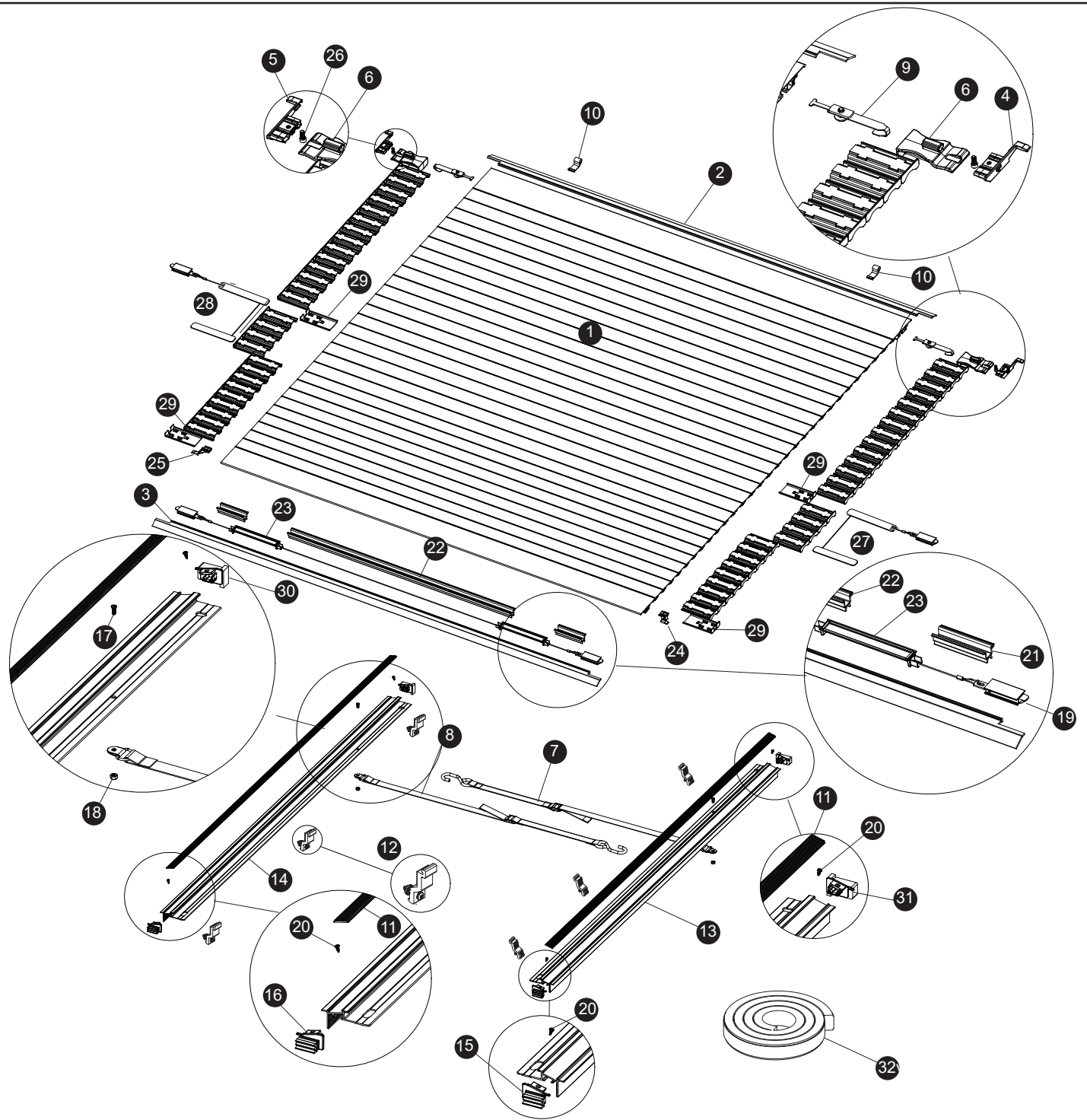

### HARD ROLL-UP TONNEAU COVER REPLACEMENT PARTS

1	*	Replacement Cover	12	1707172	Aluminum Clamp, Single (1)	22	*	Cable Cover
2	*	Header Seal, Front		1118939	ClampFastener Pack (6)	23	1115822	Cable Guard
3	*	Header Seal, Rear	13	*	Side Rail, Passenger's Side	24	1705826	Rear Header End Plug (Passenger)
4	1705828	Front Header End Plug (Passenger)	14	*	Side Rail, Driver's Side	25	1705825	Rear Header End Plug (Driver)
5	1705829	Front Header End Plug (Driver)	15	1705851	Side Rail End Plug Assy_RH	26	1704689	Machine Screw 1/4-20 X 9/16
6	1704707	Header Guide	16	1705852	Side Rail End Plug Assy_LH	27	*	Passenger Security Latch Assy
7	1117892	Retainer Hook Strap (Passenger)	17	1705415	Cap Screw 10-24 X 1/2	28	*	Driver Security Latch Assy
8	1117893	Retainer Hook Strap (Driver)	18	1703762	Hex Nut 10-24	29	1705929	Latch Cover
9	1117594	Header Guide Retainer	19	*	Latch System	30	1118243	Side Rail End Plug_RH Foam Seal
10	1705806	Extruded Retainer Loop	20	1705629	Self Drill Screw 6-20 X 3/8	31	1118244	Side Rail End Plug_LH Foam Seal
11	*	Hook and Loop Fasteners	21	1118225	Cable Cover 3.75"	32	1118371	Bulkhead Seal

\* Please specify length or make and model of vehicle.